

POSITIONING TACKLE TWILL NUMBERS ON JACKETS

RAGLAN STYLE SLEEVE:

THE SLEEVE CONTINUES IN ONE PIECE TO THE COLLAR SO THAT THERE IS NO SEAM AT THE SHOULDER.

THIS STYLE INCLUDES OUR K18, K18A AND K15.

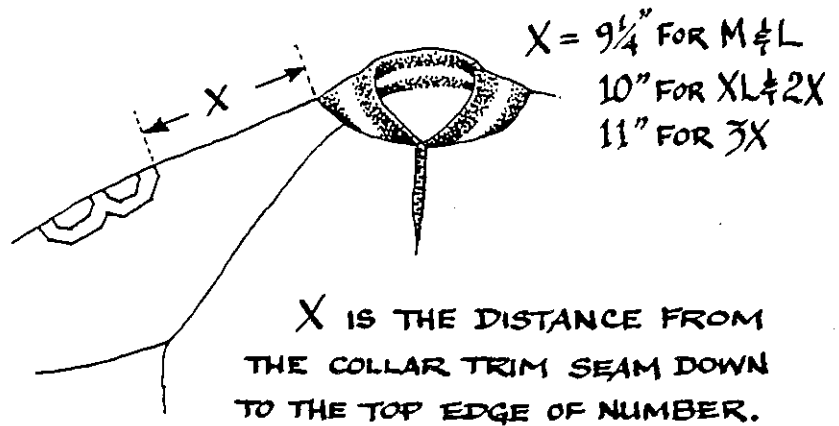

K14 WINDSHIRT:

THE SLEEVE HAS A SHOULDER SEAM LIKE OUR PULLOVER SHIRTS.

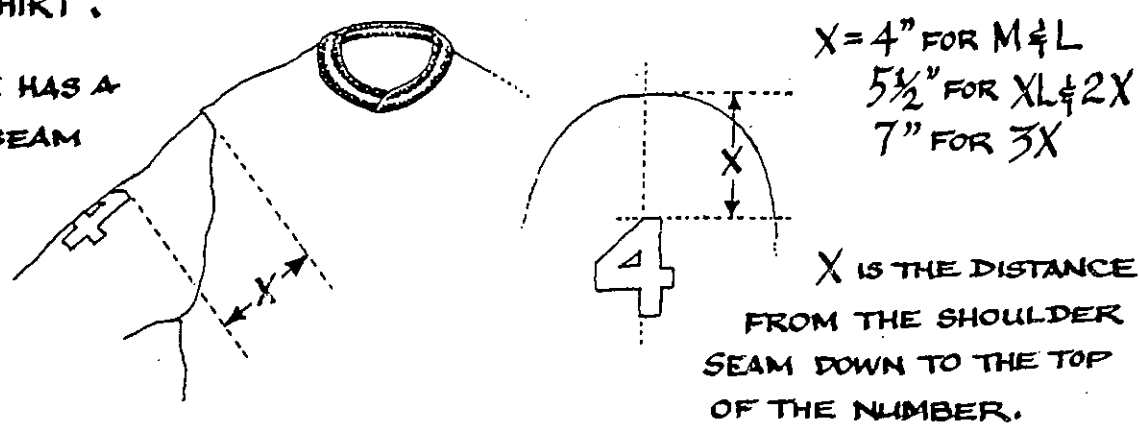

MAJOR LEAGUE STYLE PULLOVER JACKET:

THIS JACKET HAS A KNIT BAND OF TRIM BETWEEN THE SHOULDER AND SLEEVE.

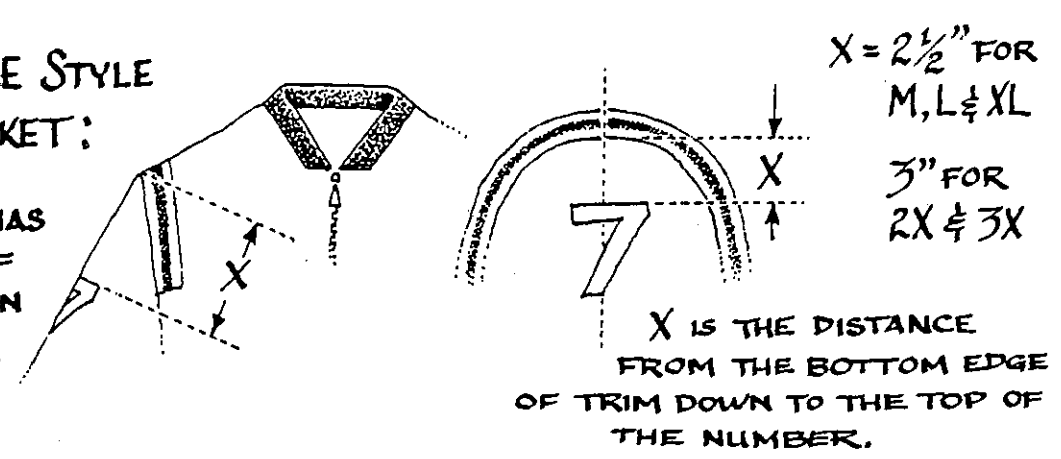

USE THE IRONING AND STITCHING DIRECTIONS FROM THE OTHER SHEET. (PRESS AT 350° FOR 10 SECONDS AND SEW DOWN WITH ZIG ZAG STITCH. WWW)

APPLICATION OF TACKLE TWILL and PLACKETS on SHIRTS

PLACE TT NUMBERS AS PER DIAGRAM AT RIGHT. THE CENTER LINE IS THE CREASE ON THE ARM WHEN YOU LAY THE SHIRT FLAT ON A TABLE. NEXT, FLATTEN THE SLEEVE SO THAT CREASE LINE IS CENTERED ON THE SIDE OF SLEEVE. USE THE DIAGRAM FOR NUMBER PLACEMENT. NOTE THAT SHORT SLEEVE SHIRTS ARE ALL MEASURED FROM THE TOP EDGE OF THE CUFF TO THE BOTTOM

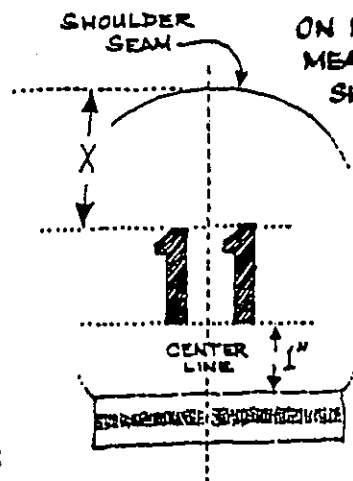

ON LONG SLEEVE SHIRTS
MEASURE DOWN FROM
SHOULDER SEAM TO THE
TOP EDGE OF NUMBER.

X = 4" FOR M & L
5½" FOR XL & 2X
7" FOR 3X

ON SHORT SLEEVE
SHIRTS THE BOTTOM
EDGE OF NUMBER IS
1" ABOVE THE CUFF.

EDGE OF THE NUMBER(S) WHILE LONG SLEEVE MEASUREMENT IS FROM THE SHOULDER SEAM TO THE TOP EDGE OF THE NUMBER(S) & DISTANCE DEPENDS ON SHIRT SIZE. IN BOTH CASES OUTSIDE EDGES OF NUMBERS SHOULD BE APPROX. SAME DISTANCE FROM THE CENTER LINE. COVER W/ PRESS CLOTH OR PILLOW CASE. PRESS W/ 350° (COTTON BETTING) IRON FOR 10 SECONDS. TIME MAY BE LONGER OR SHORTER, DEPENDING ON THE FABRIC, TO MAKE TACKLE TWILL STICK. SEW NUMBERS DOWN. THE ZIG ZAG STITCH (M/V) IS PREFERRED.

PLACE PLACKET ON BACK OF SHIRT W/ TOP EDGE 2", 3" OR 4" BELOW THE COLLAR SEAM (DISTANCE DETERMINED BY SHIRT SIZE - SEE DRAWING ON RIGHT). USE THE STRIPES ON SHIRT FOR CENTERING PLACKET. PIN THE PLACKET DOWN CAREFULLY W/ SEVERAL STRAIGHT PINS. SEW DOWN USING STRAIGHT STITCH.

